

TECHNICAL DATA

TANDEM ROLLERS

BW 154 APO-5, BW 174 APO-5

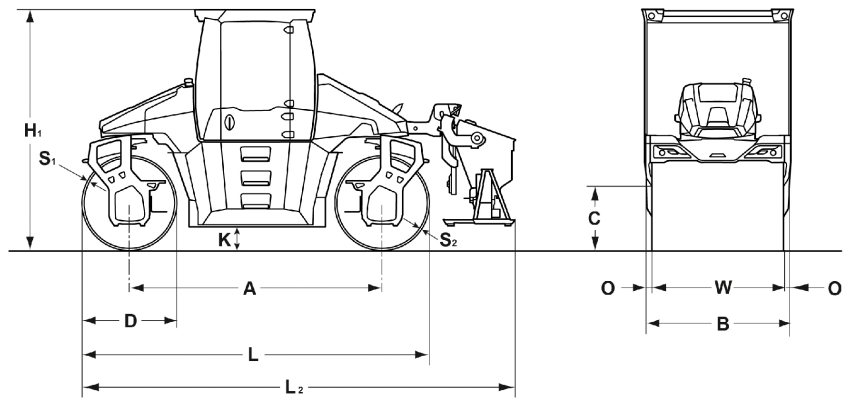



Dimensions in mm

	A	B	C	D	H1	K	L	L2	O	S1	S2	W
BW 154 APO-5	2890	1680	790	1100	3020	260	3990	5030	90	16	18	1500
BW 174 APO-5	3220	1860	810	1200	3050	280	4420	5520	90	18	20	1680

Shipping dimensions in m3

BW 154 APO-5
BW 174 APO-5

with cabin

20,244
 25,075

Machine type	Compaction output (t/h) at different asphalt layer thicknesses		
	2-4 cm	6-8 cm	10-14 cm
BW 154 APO-5	30-60	60-130	80-160
BW 174 APO-5	50-110	90-180	140-210

Technical Data**BOMAG
BW 154 APO-5****BOMAG
BW 174 APO-5****Weights**

Operating weight CECE w. ROPS-cabin	kg	7.950	9.700
Axle load, front / rear CECE	kg	3.850/4.100	4.700/5.000
Static linear load, front / rear CECE	kg/cm	25,7/27,3	28,0/29,8
Max. weight	kg	10.500	12.500

Dimensions

Track radius, inner	mm	2.950	2.970
---------------------------	----	-------	-------

Driving Characteristics

Speed	km/h	0- 11,0	0- 11,0
-------------	------	---------	---------

Drive

Engine manufacturer		Kubota	Deutz
Type		V3307 -T	TCD 3.6
Emission stage		Stage V / TIER4f	Stage V / TIER4f
Exhaust gas aftertreatment		DOC+DPF	DPF+SCR
Cooling		Liquid	Liquid
Number of cylinders		4	4
Fuel		Diesel	Diesel
Performance ISO 14396	kW	55,4	74,4
Performance SAE J 1995	hp	74,2	99,6
Speed	min-1	2.400	2.200
Split drum		front + rear	front + rear

Brakes

Service brake		hydrost.	hydrost.
Parking brake		mech.	mech.

Steering

Steering system		2-p. pivoted	2-p. pivoted
Lateral displacement right/left	mm	1.130	1.360

Exciter system

Vibrating drum		front	front
Autom. vibr. shut off		standard	standard
Frequency	Hz	44/45	44/45
Amplitude	mm	0,73/0,41	0,62/0,35
Centrifugal force	kN	89/48	89/48
Oscillating drum		rear	rear
O. Frequency	Hz	45	45
O. Amplitude	mm	0,82	0,83

Sprinkler System

Type of sprinkling		pressure	pressure
--------------------------	--	----------	----------

Capacities

Fuel	l	180,0	180,0
Water	l	550,0	680,0

Technical modifications reserved. Machines may be shown with options.

Standard Equipment

- Front drum vibration: 2 amplitudes / 2 frequencies
- TanGO Rear drum Oscillation: 1 Amplitude/ 1 Frequency
- Highly wear resistant oscillation drum
- ECOMODE
- Water-saving pressure sprinklers
- 10" Touchscreen
- Vibration and oscillation individually switchable
- 2 amplitudes / 2 frequencies
- Autom. vibration operation
- 4 spring-loaded hinged scrapers
- Indicator and hazard lights
- ROPS cabin with seat belts + heating
- 2 Outside mirrors
- Steering method/Operator's seat sliding / rotatable (270°)
- Steering with comfort control - 5 Steering modes
- Back-up alarm
- Emergency STOP
- Brake release device
- Split drums

Optional Equipment

- ECONOMIZER
- Edge cutter
- Rotary beacon
- Special paint
- Environmentally compliant hydraulic oil
- Tool kit
- Precision spreader
- Precision spreader laterally slidable
- Automatic air conditioning
- Radio/Radio preparation
- LED lighting package
 - additional lateral lighting for cabin
 - Follow-me-home function
 - Lighting for drum edge
 - 2x 12V sockets in supports
- Backup warning buzzer with broadband technology
- Additional outside mirrors
- Air-suspended comfort seat
- BOMAG TELEMATIC POWER
- BOMAG ECOSTOP
- BOMAP compaction navigation with GPS
- JOBLINK measuring technology interface
- BOMAP GPS antenna set
- BOMAP GPS antenna holder

